

INDUSTRIAL CLUTCH MOTOR

PARTS NOMENCLATURE

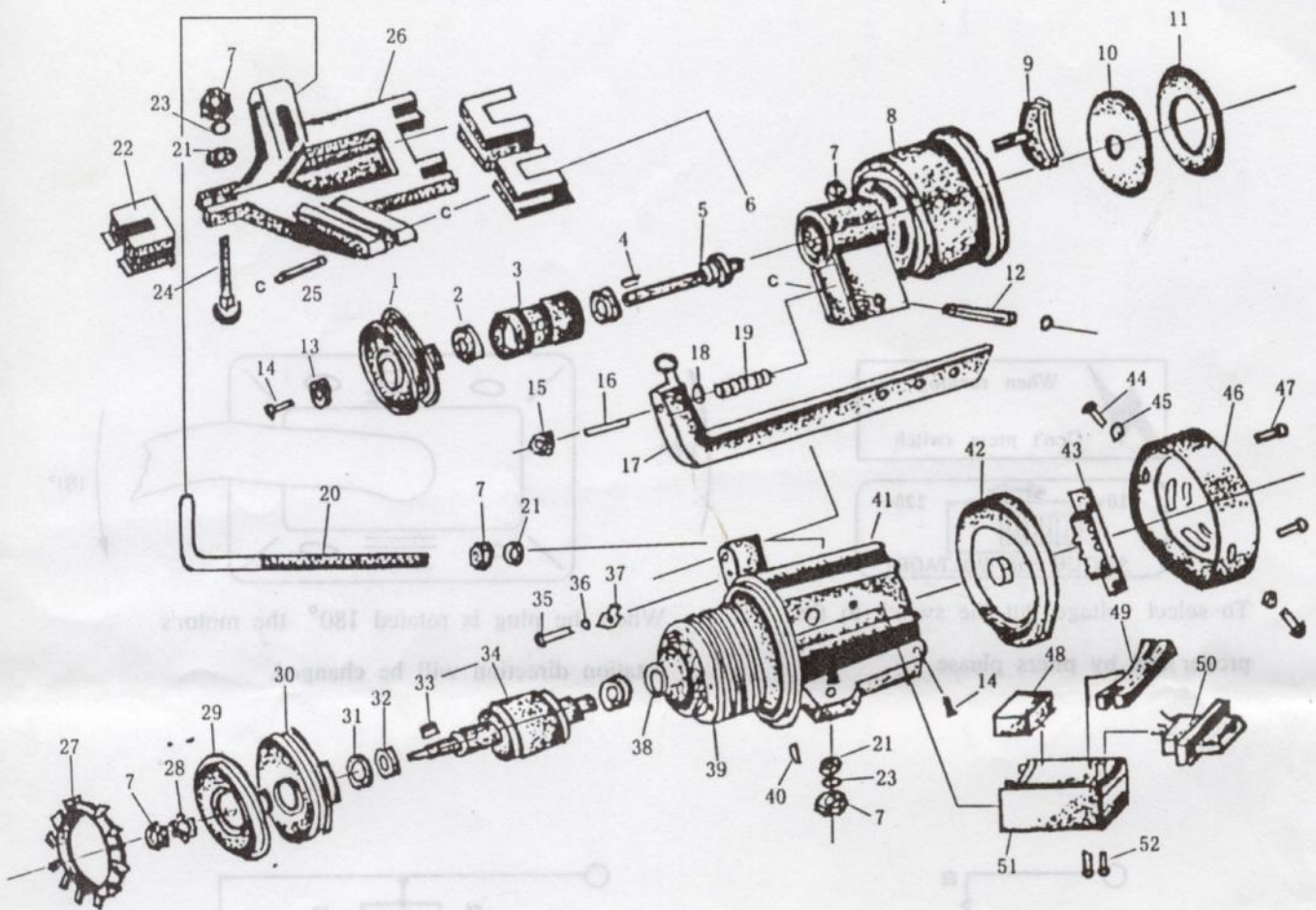

Item No.	Part Name	Item No.	Part Name	Item No.	Part Name	Item No.	Part Name
1	Pulley	16	Lock screws 6×20	31	Thrust spring ring	46	End cover
2	Bearing #6200	17	Clutch arm	32	Bearing #6000	47	Screws 3×8
3	Clutch sleeve	18	Flat washer 3	33	Key 4×10	48	Capacitor (iPholny)
4	Key 4×8	19	Coil Spring	34	Rotor	49	Socket lock washer
5	Clutch shaft	20	Beltad just mentbolt	35	Screws 5×16	50	Socket
6	E-Ring Φ 6	21	Flat washer 8	36	Spring washer 5	51	Copacitor cover
7	Lock nut 8	22	Absorber	37	Lock washer	52	Screws 3×15
8	Bracket	23	Spring washer 8	38	Cushion plate	53	
9	Brake shoe	24	Mounting bolt	39	Stator	54	
10	Clutch plate	25	Arm pin	40	Lockscrews 4×	55	
11	Clutch cork	26	Table mount	41	Housing	56	
12	Arm Pin	27	Fan blade	42	End bracket	57	
13	Lock washer	28	Spring washer	43	Move switch	58	
14	Screws 4×10	29	Flywheel	44	Screws 4×8	59	
15	Lock nut 6	30	Middle bracket	45	Spring washer 4	60	